

# Rain Barrel Application for Permit

Owners Name: \_\_\_\_\_

Date Applied For: \_\_\_\_\_

Owners Address: \_\_\_\_\_

Phone Number: \_\_\_\_\_

Contractor Name: \_\_\_\_\_

Phone Number: \_\_\_\_\_

**All application must have attached a detailed site plan that includes all pertinent information listed below.**

## **RAIN BARRELS**

One or more downspout(s) may be diverted into an approved rain barrel provided that overflow from such appurtenance is directed back into the downspout. Rain barrels shall be covered at all times and shall not cause a public or private nuisance. Rain barrels shall not be installed in the front or side yard setbacks, but are to be located only on rear yard downspouts, excepting that, rain barrels may be placed in a side yard setback, if it can be demonstrated to the satisfaction of the Building Commissioner, that due to the configuration of the structure, the rain barrel would not be visible from the public right of way or cause a public or private nuisance. Rain barrels are to be positioned adjacent to the rear of the dwelling structure so as to not be visible from the public right of way. Only one rain barrel may be installed at each rear yard downspout. A rain barrel is to be composed of HDPE Plastic, minimum size of 40 gallons, maximum size of 55 gallons, with a secure top. Rain barrel installations require the review and approval of the Building Commissioner or his/her authorized representative.

**Plans submitted for review and approval shall include a site plan drawn to scale, showing the structure in relation to the property lines and the location of the downspout(s) proposed to be used for the rain barrels, along with details of the type and size of the rain barrel and the method of connecting the overflow back to the downspout. A landscaping plan may be necessary if the rain barrel(s) need to be screened from view form the public right of way.**

**By signing as the applicant I am acknowledging that I am authorized to pull this permit for the Company listed above. (Homeowner affidavit must be signed/witnessed in the Building Department if homeowner is doing work listed above. Affidavit must be attached to this application.)**

\_\_\_\_\_  
**Signature of applicant**

\_\_\_\_\_  
**Address of Applicant**

\_\_\_\_\_  
**Date**

\_\_\_\_\_  
**Printed Name of Applicant**

\_\_\_\_\_  
**Phone Number**

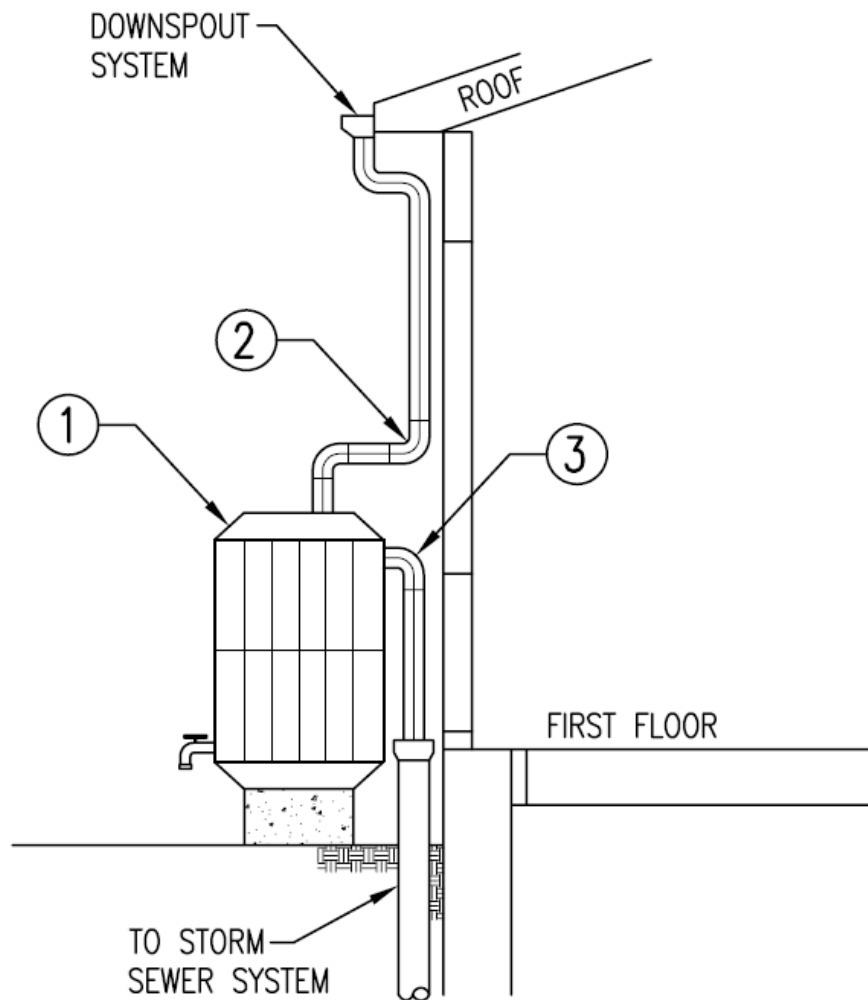

- ① RAIN BARREL (HDPE PLASTIC),  
MIN. 40 GAL. WITH SECURE TOP
- ② CUT EXIST. DOWNSPOUT, INSTALL ELBOWS  
TO DIVERT FLOW INTO RAIN BARREL
- ③ OVERFLOW INTO BASE OF DOWNSPOUT.  
USE ELBOW, CONNECT AT TOP OF BARREL

## RAIN BARREL DETAIL CITY OF LYNDBURST

THE RAIN BARREL MUST BE LOCATED  
DIRECTLY UNDER THE DOWNSPOUT